

Lido 14 Class Sloop Approved Racing Measurements

Revised March, 2002, dlc
Revised April 19, 2002, jap
Revised June 25, 2002, jap

DO NOT SCALE
Drawing original on Autosketch V 7.0
Cleanup. Revised notes. Added hull#
Corrected CB LE to Transom dimension

CENTERBOARD DETAIL

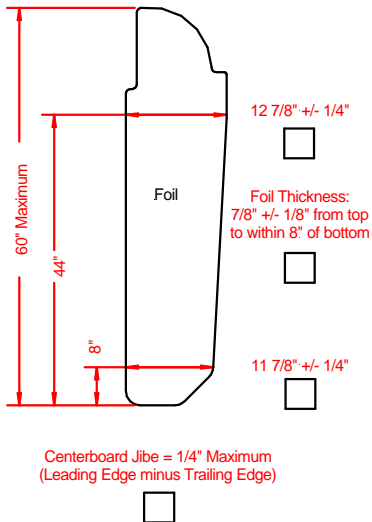

- NOTES:
1. Maximum length is 60" excluding fittings and hangers.
 2. Maximum thickness is 1" except trailing edge at keel (A/C # 54).
 3. Essential dimensions are measured without removing the board.
 4. Chord dimensions are perpendicular to the leading edge at 8" and 44" locations from the tip.
 5. Shape of bottom 8" is unrestricted.

BRIDLE-TRAVELER / TRANSOM DETAIL

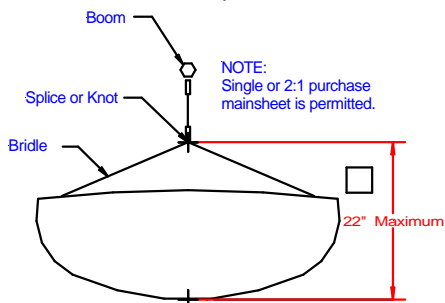

RUDDER DETAIL

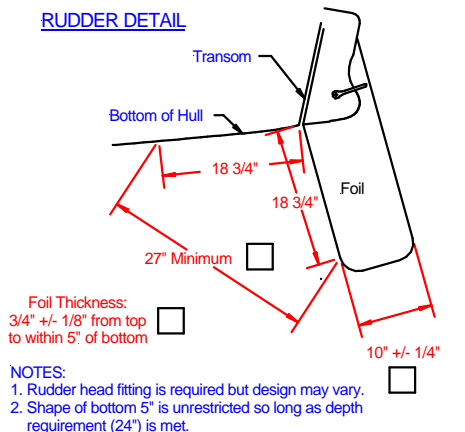

NOTE:
Mast tangs, such as Ronstan RF-43A, are permitted at mast end of shroud and forestay rigging. In the case of RF-43A, dimensions are to the tang's lower mounting hole.

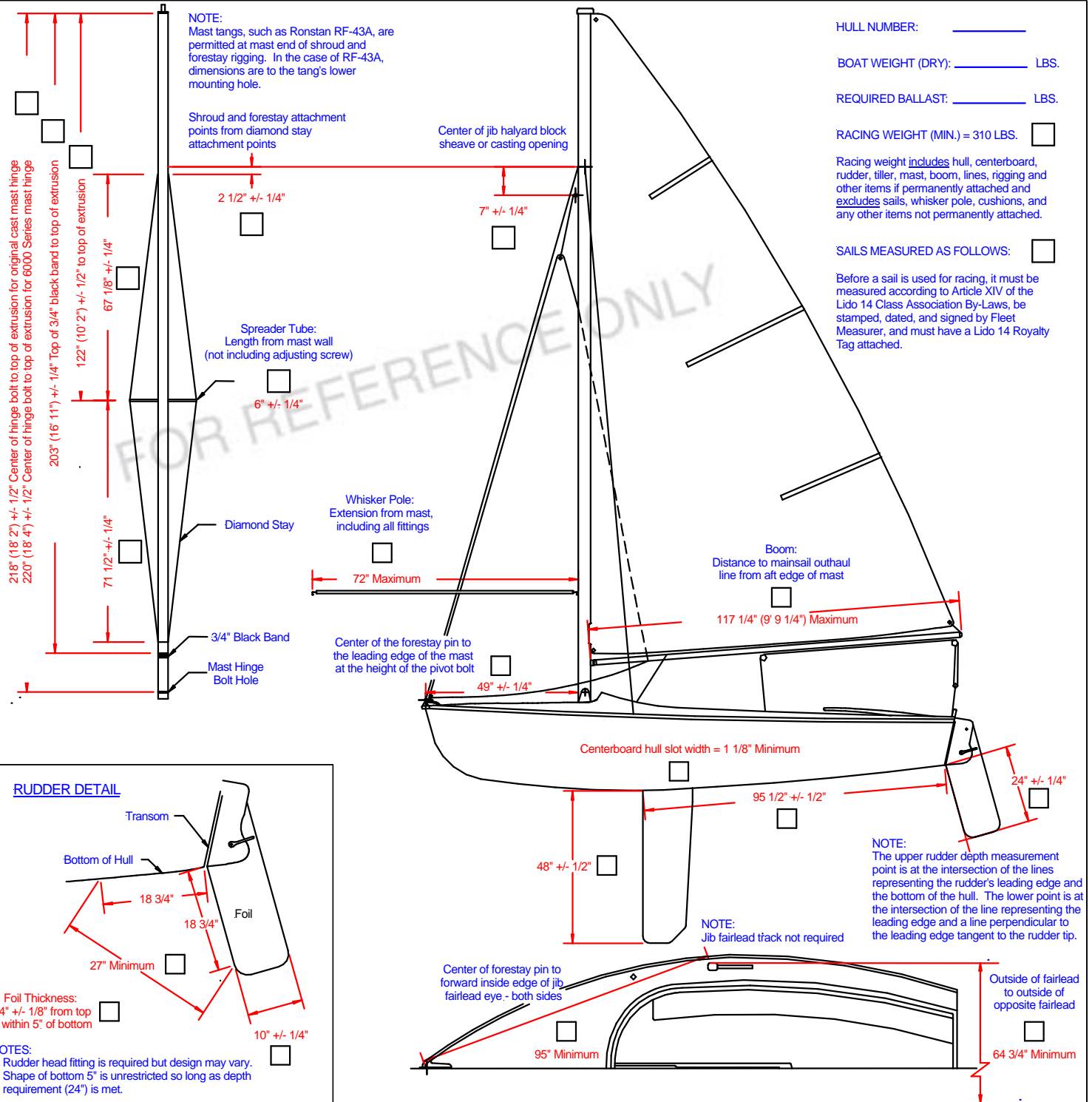

HULL NUMBER: _____

BOAT WEIGHT (DRY): _____ LBS.

REQUIRED BALLAST: _____ LBS.

RACING WEIGHT (MIN.) = 310 LBS.

Racing weight includes hull, centerboard, rudder, tiller, mast, boom, lines, rigging and other items if permanently attached and excludes sails, whisker pole, cushions, and any other items not permanently attached.

SAILS MEASURED AS FOLLOWS:

Before a sail is used for racing, it must be measured according to Article XIV of the Lido 14 Class Association By-Laws, be stamped, dated, and signed by Fleet Measurer, and must have a Lido 14 Royalty Tag attached.